

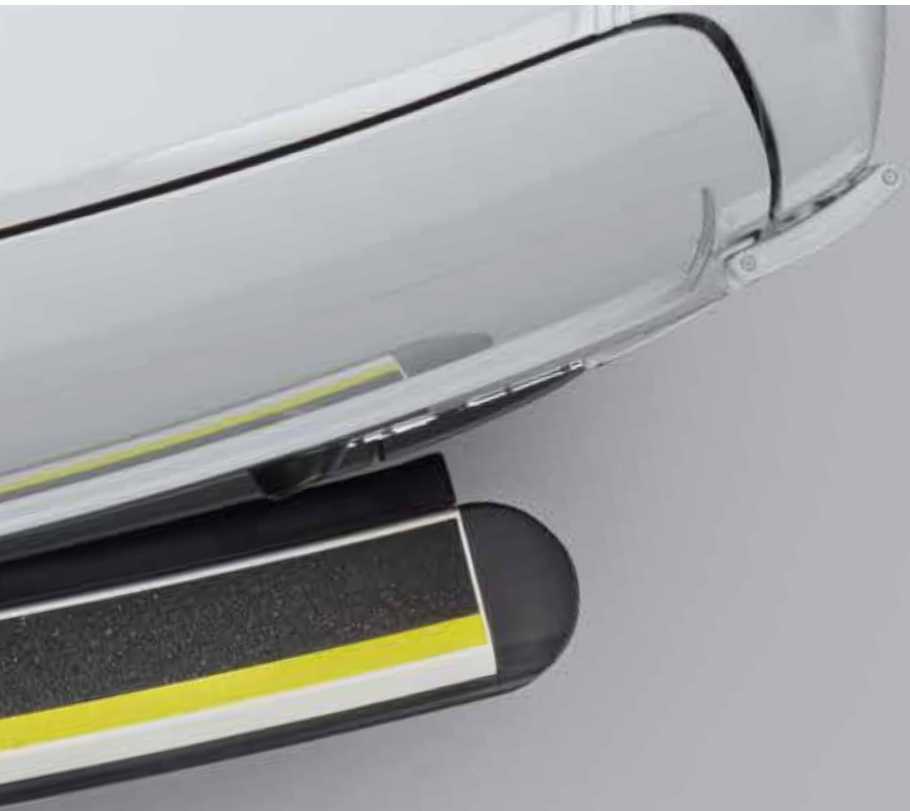

ImpactStep™





# ImpactStep™

The ImpactStep™ has been designed to protect your vehicle from low-speed parking and loading impacts.

ImpactStep™ can reduce the lifetime cost of ownership of your van by significantly reducing body repair costs and vehicle down-time.

Independently tested up to 3mph on a fully laden Mercedes Sprinter, the ImpactStep™ can resist an impact of up to 6 tonnes.

The step has been engineered to achieve a safe failure mode to minimise any significant damage occurring to the vehicle chassis.

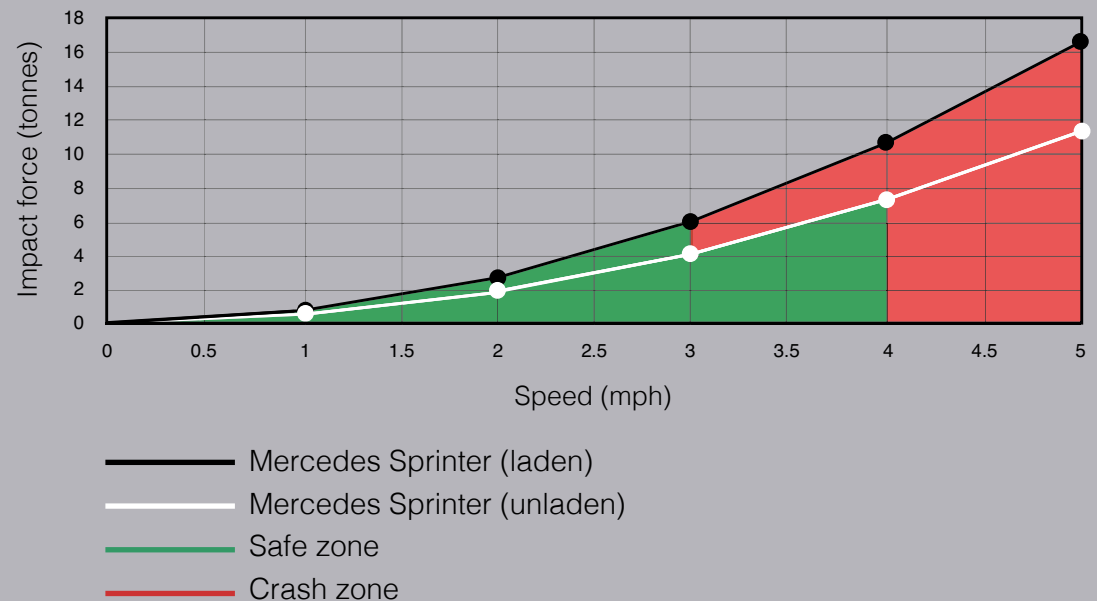



## ImpactStep™

Standard

### Features & Benefits:

- Protects the rear of the vehicle upon impact
- Twin rubber buffer shock absorbers utilised
- Shock absorption of up to 60mm compression
- Unique pivoting bracket design absorbs corner impact
- Independently laboratory impact tested
- Quick and simple fitting installation
- Full width step design with large safety tread area
- Anti-slip gripping surface with high visibility reflective strip





## TowStep™

### Features & benefits:

- Quick & simple removable centre section
- Full width step design with large safety tread area
- Substantial 110° turning angle for attached trailers
- Compliant with UN ECE Regulation 55
- Maximum load weight 136kg
- Product weighs only 15kg
- Integrated single/twin electric mounts
- Independently life cycle tested
- Manufactured from heavy duty plastic composite, mounted onto a robust steel frame
- Industry leading, unique 2 coat process of electro-paint primer and polyester black powder coating ensures maximum corrosion resistance
- Anti-slip tread plates to ensure maximum grip in all weather conditions



Compatible towballs	
TS01	Bradley Universal Couplings Ball and Pin
	Bradley Jaw and Pin
	Standard towball

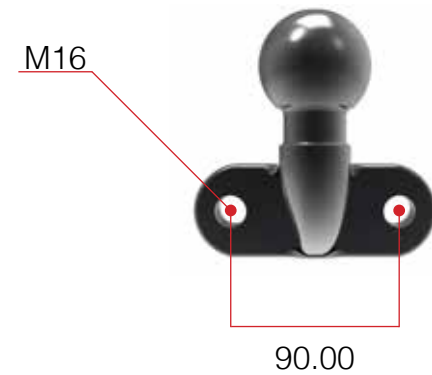
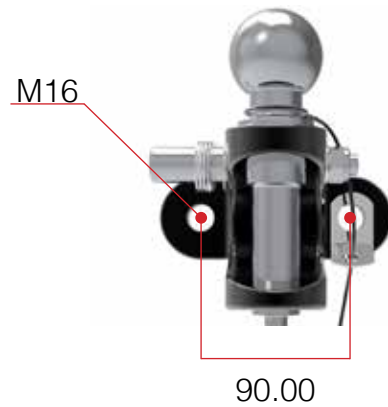



## TowStep duo™

### Features & benefits:

- Twin width step design with safety tread area  
\*no centre section included in order to accommodate Euro 4 bolt fixing towball\*
- Substantial 110° turning angle for attached trailers
- Compliant with UN ECE Regulation 55
- Maximum load weight 136kg
- Product weighs only 11kg
- Integrated single/twin electric mounts
- Independently life cycle tested
- Manufactured from heavy duty plastic composite, mounted onto a robust steel frame
- Industry leading, unique 2 coat process of electro-paint primer and polyester black powder coating ensures maximum corrosion resistance
- Anti-slip tread plates to ensure maximum grip in all weather conditions



Compatible towballs	
TS02	Continental/Euro 4 bolt fixing towball
	Continental/Euro 4 bolt fixing Ball and Pin
	Dixon Bate Universal Couplings Ball and Pin (3.5t)
	Dixon Bate Jaw

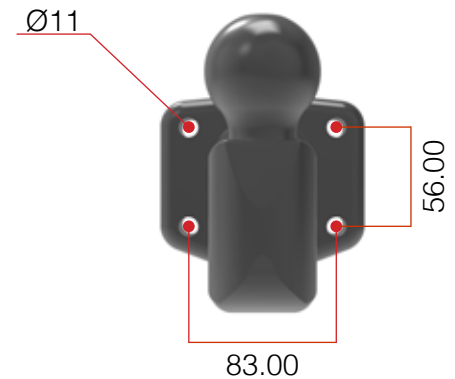
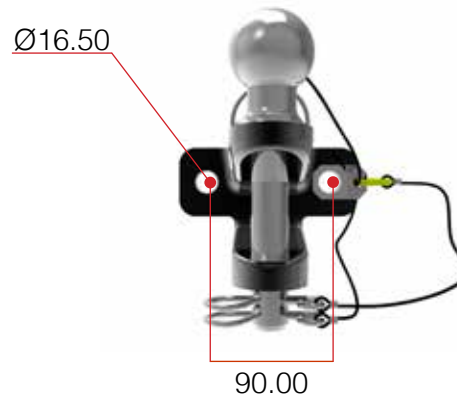





## SafeStep™

\*Available in both twin and triple steps - vehicle dependent\*

**The SafeStep™ combines a solution for areas surrounding Health & Safety, when loading/unloading roof mounted equipment or gaining access in or out of a vehicle.**

**Additionally, the SafeStep™ can provide drivers with peace of mind with optional reversing sensors with an audible warning of objects that are out of sight.**

### **Features & benefits:**

- 20g crash tested
- TUV approved
- Clear and concise fitting instructions
- Standard reflective tape on each step
- Anti-slip tread plates to ensure maximum grip in all weather conditions
- Industry leading unique 2 coat process of electro-paint primer and polyester black powder coating ensures maximum corrosion resistance





Rhino Products Ltd.  
Sixth Avenue, Zone 2  
Deeside Industrial Park  
Deeside, Flintshire  
CH5 2LB  
United Kingdom  
+44 (0) 1244 833 790  
[www.rhinoproducts.co.uk](http://www.rhinoproducts.co.uk)

Rhino Products B.V  
Kaldenkerkerweg 20  
5913 AE Venlo  
Holland  
+31 (0) 77 3510133  
[www.rhinoproducts.eu](http://www.rhinoproducts.eu)

Rhino Nordic AB  
Processvägen 2  
435 33 Mölnlycke  
Sweden  
+46 (0) 565-510 05  
[www.rhinoproducts.se](http://www.rhinoproducts.se)

